

Dynamics and Vibrations Ph.D. Qualifying Exam

Spring 2012

Instructions:

Please work 3 of the 4 problems on this exam. It is important that you clearly mark which three problems you wish to have graded. For the three problems that you select, show all your work in order to receive proper credit. You are allowed to use a calculator.

Be sure to budget your time; concentrate on setting up the problem solution first and leave algebra until the end. When necessary, you may leave your answers in terms of unevaluated numerical expressions. Good Luck!

Problem 1

A long, thin, 176 kg platform whose length is $L = 11.9$ meters has been rigged across a ravine using two ropes OA and PB , as shown in the figure. Each rope has a length of 4.08 meters and is inclined at an angle of $\theta = 39$ degrees. Due to a sudden failure at the attachment point P , the platform begins to fall.

Immediately after the failure at P , determine: (a) the angular acceleration of the platform and (b) the tension in the remaining rope OA .



Problem 2

A balanced wheel, spinning in the horizontal plane (gravity parallel to the axis of rotation) is constrained such that only motion in the x direction is permitted. The wheel is spinning at 1200 revolutions per minute. If a nut weighing 15 g and located 5 cm from the center of the wheel suddenly comes loose and flies off as the nut passes through the position $\theta=0$, determine the build-up of the vibration if the natural frequency of the system is 18 Hz and with damping $\zeta=0.10$. What modification would you have to make in your analysis if the wheel was spinning in the vertical plane, with gravity (do not repeat the full analysis; comment on any other considerations that come into play).

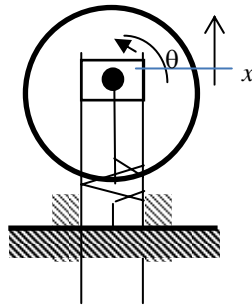

Problem 3

A bicycle is traversing a circular path of radius R at a constant speed v and lean angle of θ . The front wheel of the bicycle shown in the figure has radius r , polar moment of inertia $I_{zz}=J$, and axial moment of inertia $I_{xx}=I_{yy}=I$. Assuming the wheel rolls without slipping, find

- The angular velocity and acceleration of the wheel.
- The net moment $\Sigma \mathbf{M}_C$ about the wheel centroid C needed to sustain its motion.

Please clearly state all the assumptions you have to make as well as any additional variables that you may need to introduce.

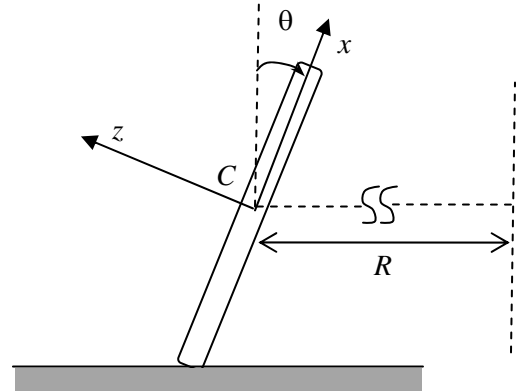

Problem 4

A uniform elastic rod of length L , Young's modulus E , density ρ , cross-sectional area A is fixed at either end as shown. We wish to approximate the continuous system with a lumped approximation consisting of 2 masses and 3 springs as shown. Note that the formula for the stiffness of a rod segment of length ℓ is simply EA/ℓ .

- Give reasonable expressions for the masses and springs of the lumped approximation in terms of the system parameters E , A , ρ , and L .
- Find the natural frequencies and natural modes of the lumped system.
- If mass 1 is held and mass 2 is given a slight displacement and then released, sketch the response of the coordinates x_1 and x_2 capturing the qualitative features of the free response. You may assume that the system is undamped.
- Compare your answers in (b) with the exact natural frequencies of the uniform, fixed-fixed rod. Are the approximations greater than or less than the exact values?

